

MODEL: L-030

ANSI RATING:	ANSI Z 245.60-1996
LIFT TYPE:	ROTARY ACTUATOR
HYDRAULIC FLOW:	2 - 3 GPM
CYCLE TIME:	8-10 SECONDS
MAX. LOAD WEIGHT:	250 LBS
OPTIONS:	TAP-IN-KIT
HYDRAULIC PRESSURE:	WORKING PRESSURE - 1800 PSI - 2100 PSI
CART COMPATIBILITY:	TYPE B CARTS (DOMESTIC STYLE 2-BAR)

**Few Moving Parts for Easy Service & Maintenance**

The **A-100** is designed to operate with fewer moving parts to delivers all the safety and reliability you need. The **A-100** is designed to operate with fewer moving parts to delivers all the safety and reliability you need. Lifts most Domestic Style 2-wheeled Carts (up to 95 gal. - 360 liters) - accommodates manual loading as well.

- Powered by a powerful rotary actuator for a smooth, reliable operation under continuous use, (up to 800 cycles per shift.)
- The A-100 is designed to operate with fewer moving parts to delivers all the safety and reliability you need.
- Thin profile for mounting on side loaders.
- Lifts most Domestic Style 2-wheeled Carts (up to 95 gal. - 360 liters) - accommodates manual loading as well.
- Original sweeping action automatically adjusts to varying heights and uneven terrain allowing operators to mount carts securely onto the Tipper lifting hook.
- Dumps deeper inside the hopper to prevent spillage and dumps higher to reduce the need to cycle the packer blade.
- Cannot be damaged by side loader packer blade.

Specifications are subject to change without any notice or obligation on the part of the manufacturer. While due caution has been exercised in the production of this document, possible errors and omissions are unintentional.



A-100 SERIES



The **A-100** is designed to operate with fewer moving parts to deliver all the safety and reliability you need. The A-100 is designed to operate with fewer moving parts to deliver all the safety and reliability you need. Lifts most Domestic Style 2-wheeled Carts (up to 95 gal. - 360 liters) - accommodates manual loading as well.

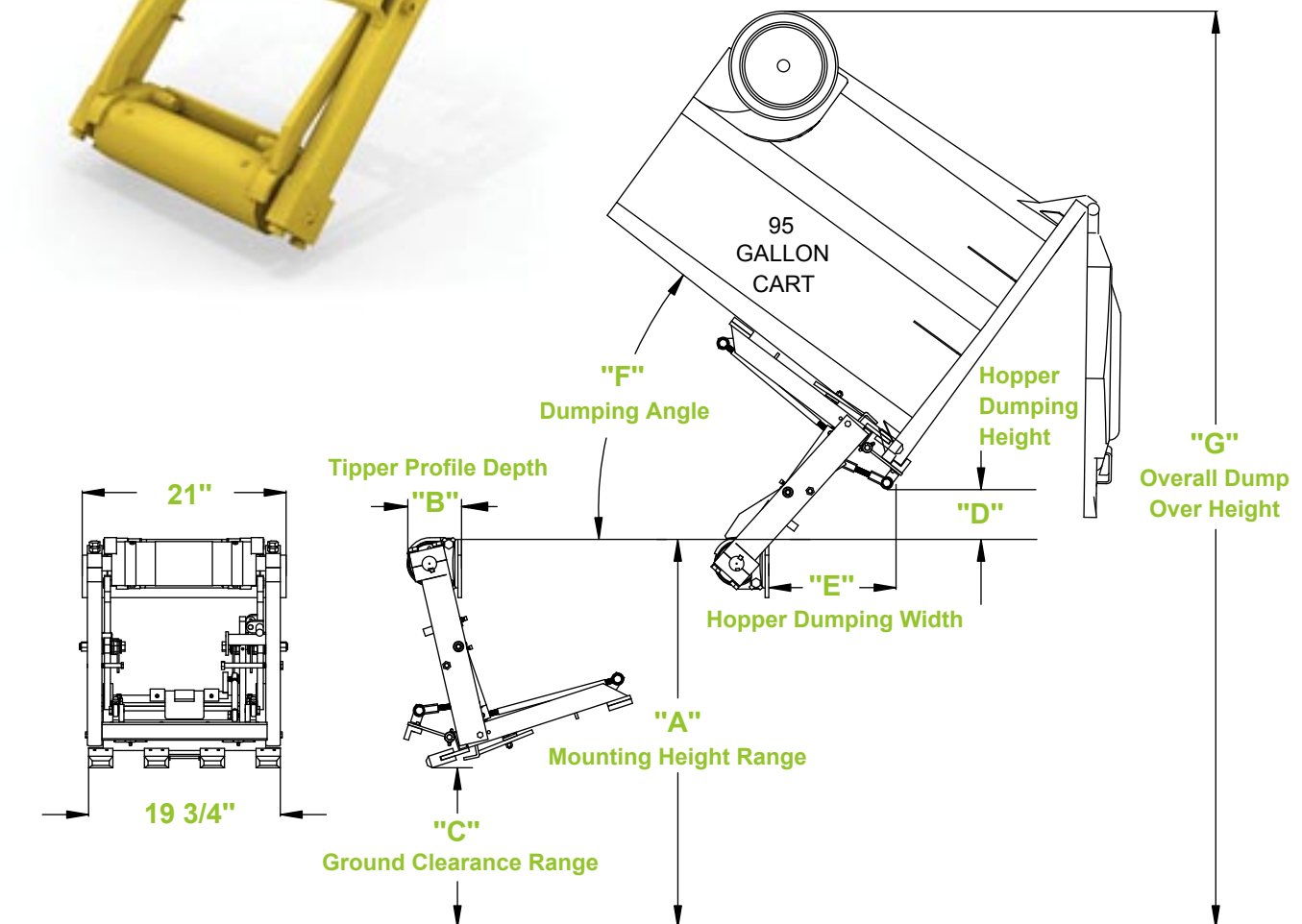

MODEL	"A" DIM.	"B" DIM.	"C" DIM.	"D" DIM.	"E" DIM.	"F" DIM.	"G" DIM.
R-130 Rear loader	38 - 44"	6"	14 1/2" - 20 1/2"	5 1/4"	18 7/8"	45°	92 1/4" - 98 1/4"
L-030 Side loader	42 - 47"	6"	14 1/2" - 19 1/2"	8 1/4"	20 7/8"	45°	99 1/4" - 104 1/2"

Dimensions accommodate most ANSI Z245.60-1996 Type B Carts (Domestic Style 2-Bar) and most ANSI Z245.60-1996 Type C Carts (European Style) Containers, but may vary due to container specifications or applications. All dimensions are approximate.



Toll Free: 1-800-711-6188