

MODEL: R-110

ANSI RATING:	ANSI Z 245.60-1996
LIFT TYPE:	ROTARY ACTUATOR
HYDRAULIC FLOW:	2 - 3 GPM
CYCLE TIME:	8-10 SECONDS
MAX. LOAD WEIGHT:	250 LBS
OPTIONS:	TAP-IN-KIT
HYDRAULIC PRESSURE:	WORKING PRESSURE - 1800 PSI - 2100 PSI
CART COMPATIBILITY:	TYPE B CARTS (DOMESTIC STYLE 2-BAR) TYPE C CARTS (EUROPEAN STYLE)

**Few Moving Parts for Easy Service & Maintenance**

- Powered by a powerful rotary actuator for a smooth, reliable operation under continuous use, (up to 800 cycles per shift.)
- The A-100 is designed to operate with fewer moving parts to delivers all the safely and reliability you need.
- Thin profile for mounting on rear loaders.
- Mounts on a removable mounting plate with minimal cutting into the sill, for easy maintenance and replacement.
- Lifts most Domestic and Euro Style 2-wheeled Carts (up to 95 gal. - 360 liters) - accommodates manual loading as well.
- Original sweeping action automatically adjusts to varying heights and uneven terrain allowing operators to mount carts securely onto the Tipper lifting hook.
- Dumps deeper inside the hopper to prevent spillage and dumps higher to reduce the need to cycle the packer blade.
- Thin Tipper profile does not interfere with commercial container lifts, tipper/kick bars or overhead winch mechanisms on rear loaders.
- Ideal for compact installations (2 lifters on the same rear loader for increased productivity) with enough clearance for commercial carts and unrestricted access to the hopper area for hand loading.

Specifications are subject to change without any notice or obligation on the part of the manufacturer. While due caution has been exercised in the production of this document, possible errors and omissions are unintentional.



A-100 SERIES



The **A-100** is designed to operate with fewer moving parts to deliver all the safety and reliability you need. Ideal for compact installations (2 lifters on the same rear loader for increased productivity) with enough clearance for commercial carts and unrestricted access to the hopper area for hand loading.

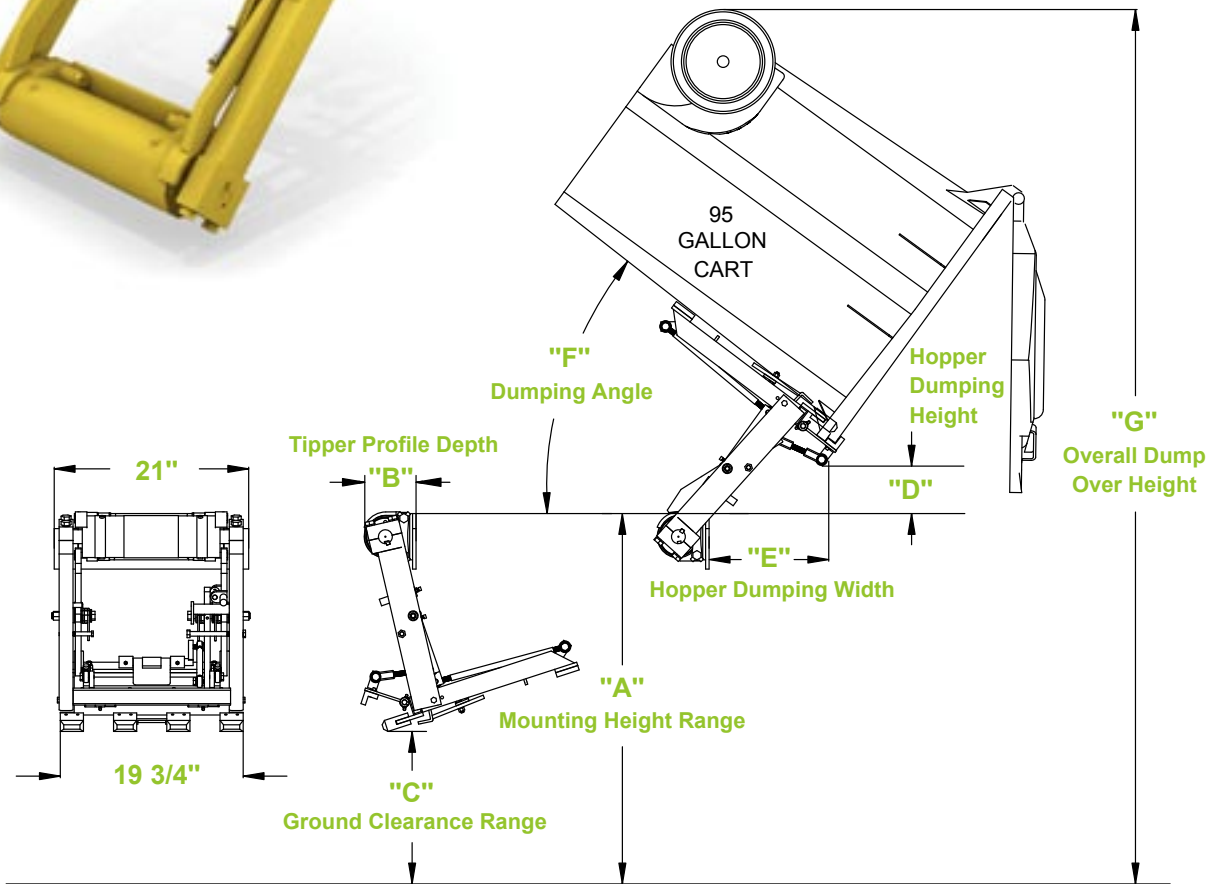

MODEL	"A" DIM.	"B" DIM.	"C" DIM.	"D" DIM.	"E" DIM.	"F" DIM.	"G" DIM.
R-110 Rear loader	38 - 44"	6"	14 1/2" - 20 1/2"	5 1/4"	18 7/8"	45°	92 1/4" - 98 1/4"
L-010 Side loader	42 - 47"	6"	14 1/2" - 19 1/2"	8 1/4"	20 7/8"	45°	99 1/4" - 104 1/2"
R-120 Rear loader	38 - 44"	6"	14 1/2" - 20 1/2"	5 1/4"	18 7/8"	45°	92 1/4" - 98 1/4"
L-020 Side loader	42 - 47"	6"	14 1/2" - 19 1/2"	8 1/4"	20 7/8"	45°	99 1/4" - 104 1/2"
R-130 Rear loader	38 - 44"	6"	14 1/2" - 20 1/2"	5 1/4"	18 7/8"	45°	92 1/4" - 98 1/4"
L-030 Side loader	42 - 47"	6"	14 1/2" - 19 1/2"	8 1/4"	20 7/8"	45°	99 1/4" - 104 1/2"

Dimensions accommodate most ANSI Z245.60-1996 Type B Carts (Domestic Style 2-Bar) and most ANSI Z245.60-1996 Type C Carts (European Style) Containers, but may vary due to container specifications or applications. All dimensions are approximate.



Toll Free: 1-800-711-6188