

MODEL: RT-220

ANSI RATING:	ANSI Z 245.60-1996
LIFT TYPE:	CYLINDER
HYDRAULIC FLOW:	2 - 3 GPM
CYCLE TIME:	8-10 SECONDS
MAX. LOAD WEIGHT:	400 LBS (180 KG)
OPTIONS:	TAP-IN-KIT
HYDRAULIC PRESSURE:	WORKING PRESSURE - 1800 PSI - 2100 PSI
CART COMPATIBILITY:	TYPE B CARTS (DOMESTIC STYLE 2-BAR) TYPE C CARTS (EUROPEAN STYLE)

**Compact Extra Long Arm Tipper**

- Cylinder-powered Tipper delivers all the performance you need, (up to 800 cycles per shift.)
- Thin profile for mounting on rear loaders.
- Mounts on a removable mounting plate with minimal cutting into the sill, for easy maintenance and replacement.
- Lifts most Domestic and Euro Style 2-wheeled Carts (up to 95 gal. - 360 liters) - accommodates manual loading as well.
- Original sweeping action automatically adjusts to varying heights and uneven terrain allowing operators to mount carts securely onto the Tipper lifting hook.
- The C-220 dumps deeper inside the hopper to prevent spillage and dumps higher to reduce the need to cycle the packer blade.
- Thin Tipper profile does not interfere with commercial container lifts, tipper/kick bars or overhead winch mechanisms on rear loaders.
- Narrow design allows for compact installations (2 lifters on the same rear loader for increased productivity) with enough clearance for commercial containers and unrestricted access to the hopper area for hand loading.
- Trunnion-mounted cylinder makes for easier mounting.

Specifications are subject to change without any notice or obligation on the part of the manufacturer. While due caution has been exercised in the production of this document, possible errors and omissions are unintentional.



C-220 SERIES



The **C-220** dumps deeper inside the hopper to prevent spillage and dumps higher to reduce the need to cycle the packer blade. Thin Tipper profile does not interfere with commercial container lifts, tipper/kick bars or overhead winch mechanisms on rear loaders.

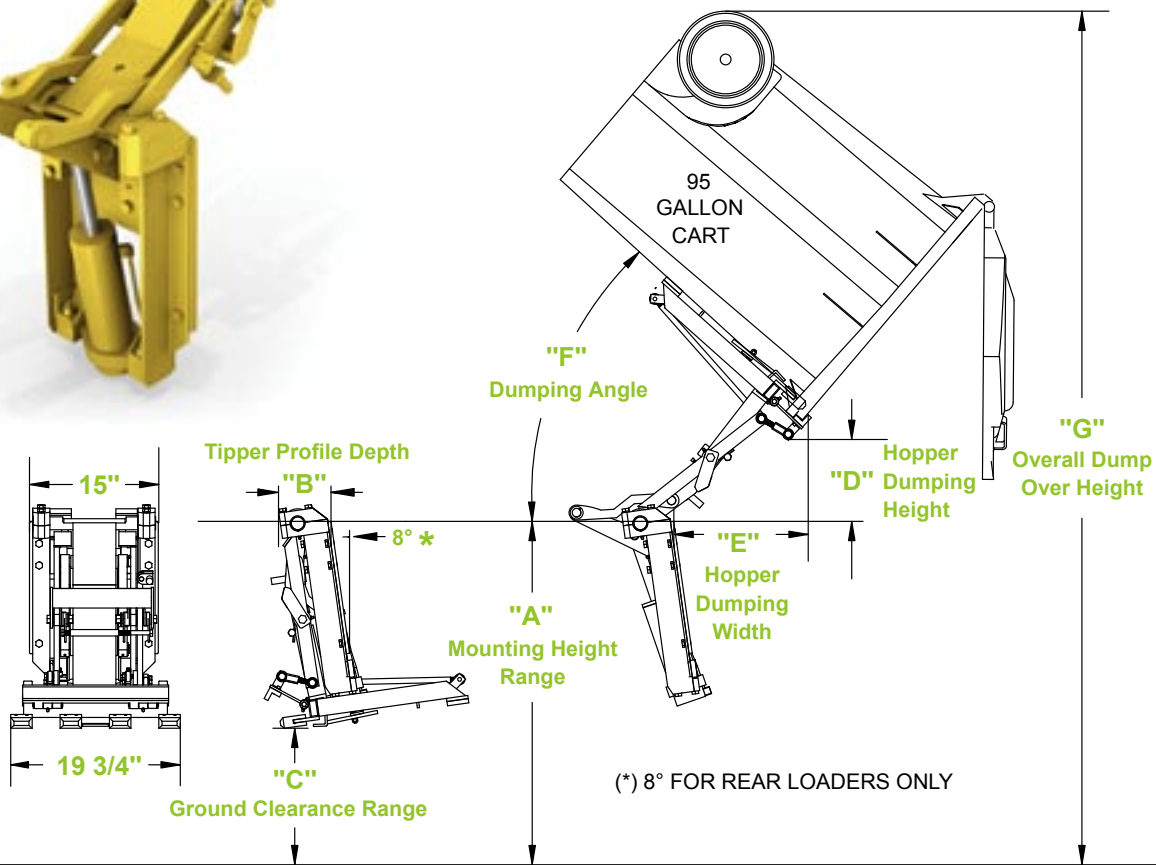

MODEL	"A" DIM.	"B" DIM.	"C" DIM.	"D" DIM.	"E" DIM.	"F" DIM.	"G" DIM.
RT-220 Rear loader	38 - 44"	6"	14" - 18'	9"	16"	45°	97" - 103"
LT-220 Side loader	42 - 47"	6"	16 ½" - 21 ½"	9"	19"	50°	101" - 106"
LXT-220 Side loader	42 - 47"	6"	12" - 17"	17"	18"	45°	109 ½" - 114 ½"
RE-220 Rear loader	38 - 44"	6"	14" - 18'	9"	16"	45°	97" - 103"
LE-220 Side loader	42 - 47"	6"	16 ½" - 21 ½"	9"	19"	50°	101" - 106"
LXE-220 Side loader	42 - 47"	6"	12" - 17"	17"	18"	45°	109 ½" - 114 ½"
RA-220 Rear loader	38 - 44"	6"	14" - 18'	9"	16"	45°	97" - 103"
LA-220 Side loader	42 - 47"	6"	16 ½" - 21 ½"	9"	19"	50°	101" - 106"
LXA-220 Side loader	42 - 47"	6"	12" - 17"	17"	18"	45°	109 ½" - 114 ½"

Dimensions accommodate most ANSI Z245.60-1996 Type B Carts (Domestic Style 2-Bar) and most ANSI Z245.60-1996 Type C Carts (European Style) Containers, but may vary due to container specifications or applications. All dimensions are approximate.



Toll Free: 1-800-711-6188