

MODELS: CD-113E

ANSI RATING:	ANSI Z 245.60-1996
LIFT TYPE:	CYLINDER
HYDRAULIC FLOW:	4 - 6 GPM
CYCLE TIME:	8-10 SECONDS
MAX. LOAD WEIGHT:	1500 LBS
OPTIONS:	TAP-IN-KIT
HYDRAULIC PRESSURE:	WORKING PRESSURE - 1800 PSI - 2100 PSI
CART COMPATIBILITY:	TYPE C CARTS (EUROPEAN STYLE) 4-WHEELED CONTAINERS

**Handles Cart and Container Systems for Side and Rear Loaders**

The **CD-113** lifts most Euro Style 2-wheeled Carts, 4-wheeled Containers including Trunnion lifts (up to 290 gal.-1100 liters) - accommodates manual loading as well. Designed to grab either one or two 2-wheeled Carts at the same time.

- Cylinder-powered Tipper delivers all the performance you need, (up to 800 cycles per shift.)
- The CD-113 lifts most Euro Style 2-wheeled Carts, 4-wheeled Containers including Trunnion lifts (up to 290 gal.-1100 liters) - accommodates manual loading as well.
- The CD-113 is designed to grab either one or two 2-wheeled Carts at the same time.
- Vertical lifting action automatically adjusts to varying heights and uneven terrain allowing operators to mount carts or containers securely onto the Tipper lifting hook.
- Lifts and dumps higher to reduce the need to cycle the packer blade.
- Cannot be damaged by the packer blade.
- For use in high dump requirements on side loaders with high sills.

Specifications are subject to change without any notice or obligation on the part of the manufacturer. While due caution has been exercised in the production of this document, possible errors and omissions are unintentional.



CD-113L *SERIES*

The **CD-113** lifts most Euro Style 2-wheeled Carts, 4-wheeled Containers including Trunnion lifts (up to 290 gal.-1100 liters) - accommodates manual loading as well. Designed to grab either one or two 2-wheeled Carts at the same time.

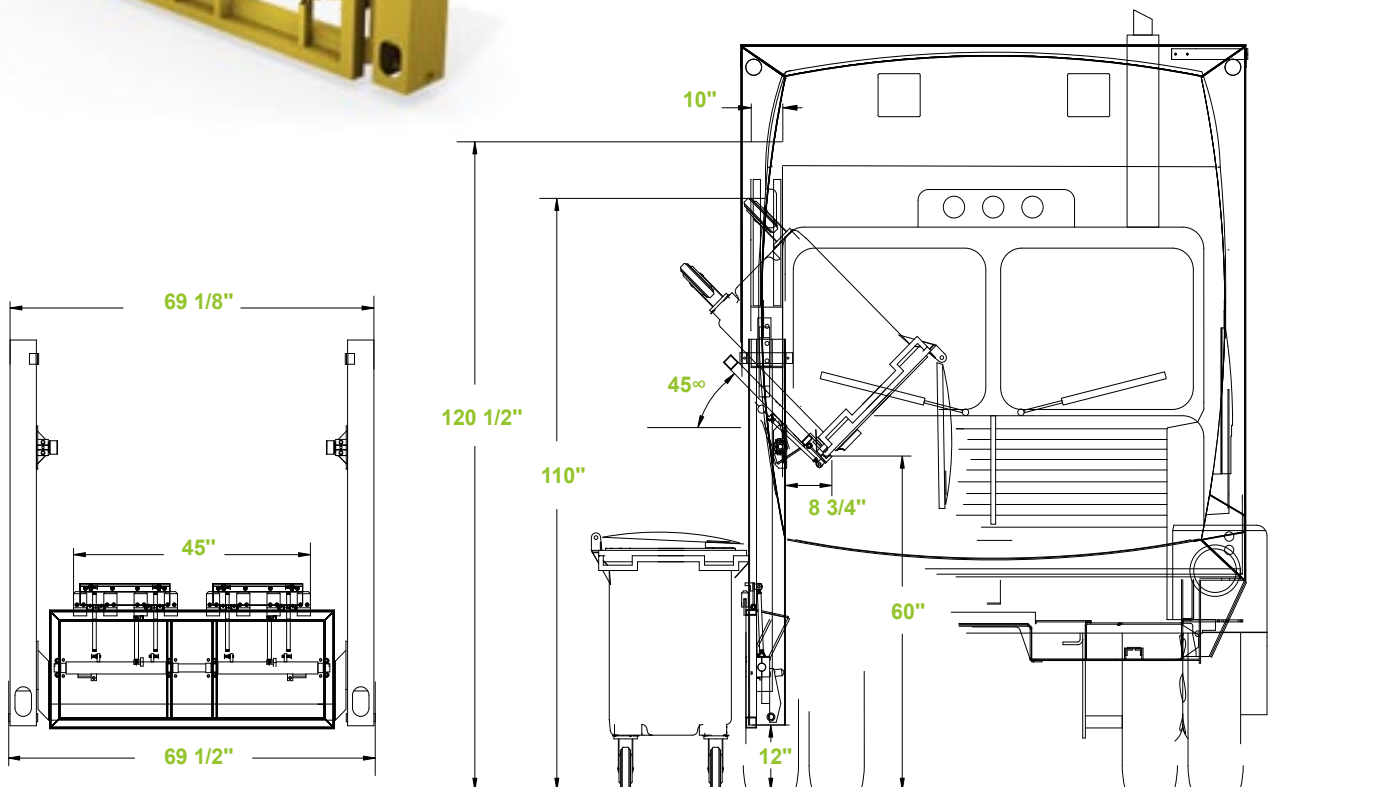

Dimensions accommodate most ANSI Z245.60-1996 Type B Carts (Domestic Style 2-Bar) and most ANSI Z245.60-1996 Type C Carts (European Style) Containers, but may vary due to container specifications or applications. All dimensions are approximate.



Toll Free: 1-800-711-6188

www.IndustrialLifters.com
© BDFG & Industrial Lifters
Printed in Canada - # GIL-121-2005