

MODEL: CDA-210

ANSI RATING:	ANSI Z 245.60-1996
LIFT TYPE:	HYDRAULIC MOTOR
HYDRAULIC FLOW:	2 - 3 GPM
CYCLE TIME:	8-10 SECONDS
MAX. LOAD WEIGHT:	400 LBS
OPTIONS:	TAP-IN-KIT
HYDRAULIC PRESSURE:	WORKING PRESSURE - 1800 PSI - 2100 PSI
CART COMPATIBILITY:	TYPE B CARTS (DOMESTIC STYLE 2-BAR)

**Latest Innovation in Cart Lifting Technology**

The **CD-210** is powered by a dependable hydraulic motor for smooth motion through the complete cycle, (up to 600 cycles per shift.) Chain lift with direct drive motor reducer provides dependable performance. Dock level dumping provides more loading versatility.

- The CD-210 is powered by a dependable hydraulic motor for smooth motion through the complete cycle, (up to 600 cycles per shift.)
- Lifts most Domestic Style 2-wheeled Carts (up to 95 gal. - 360 liters.)
- Vertical lifting action automatically adjusts to varying heights and uneven terrain allowing operators to mount carts securely onto the Tipper lifting hook.
- Dumps deep inside the hopper to prevent spillage and dumps higher to reduce the need to cycle the packer blade.
- Chain lift with direct drive motor reducer provides dependable performance.
- Dock level dumping provides more loading versatility.
- Cannot be damaged by the packer blade.

Specifications are subject to change without any notice or obligation on the part of the manufacturer. While due caution has been exercised in the production of this document, possible errors and omissions are unintentional.



CD-210 *SERIES*



The **CD-210** is powered by a dependable hydraulic motor for smooth motion through the complete cycle, (up to 600 cycles per shift.) Chain lift with direct drive motor reducer provides dependable performance. Dock level dumping provides more loading versatility.

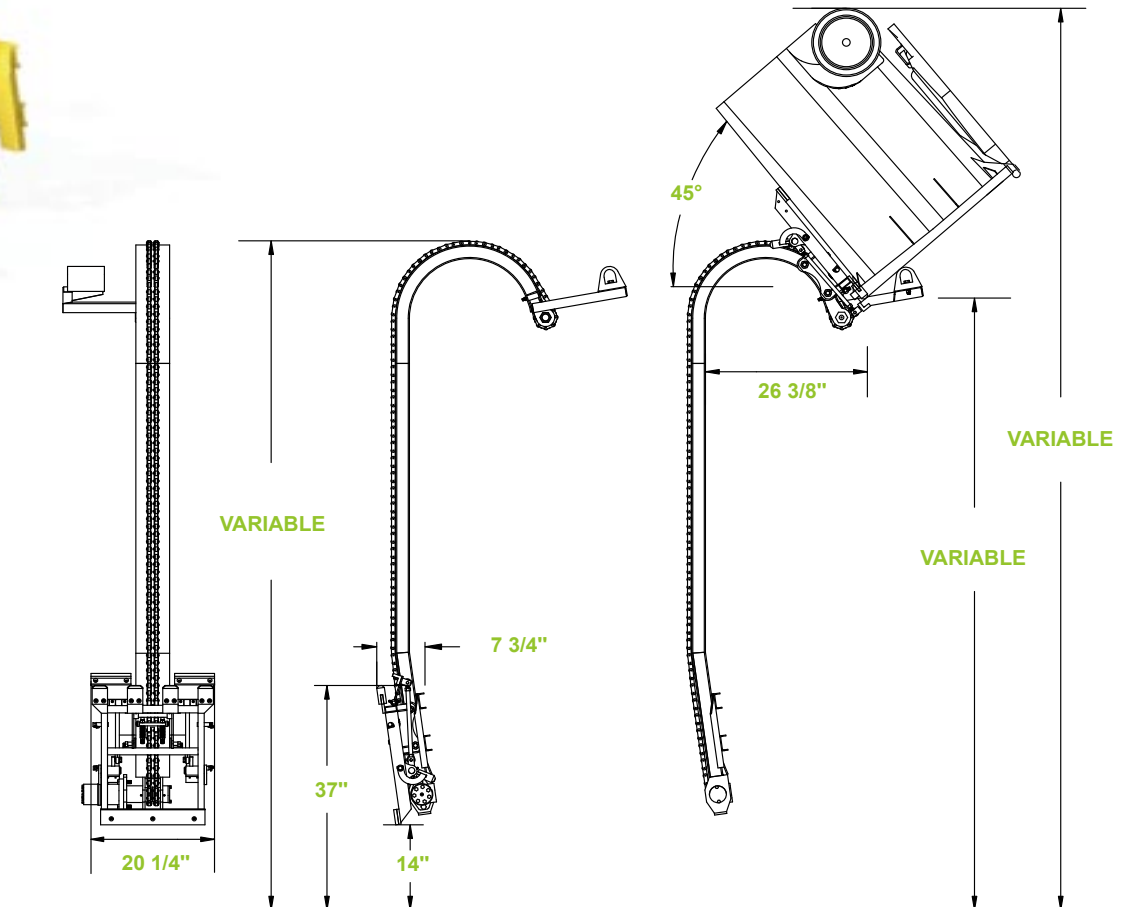

Specifications

Dimensions accommodate most ANSI Z245.60-1996 Type B Carts (Domestic Style 2-Bar) and most ANSI Z245.60-1996 Type C Carts (European Style) Containers, but may vary due to container specifications or applications. All dimensions are approximate.



Toll Free: 1-800-711-6188

www.IndustrialLifters.com
© BDFG & Industrial Lifters
Printed in Canada - # GIL-121-2005