

MODEL: LDA-220**High Efficiency Design**

The **D-220** is designed to grab either one or two 2-wheeled carts at the same time. Dumps deeper inside the hopper to prevent spillage and dumps higher to reduce the need to cycle the packer blade. Thin profile for mounting on side loaders. Lifts most US style 2-wheeled carts.

- Cylinder-powered Tipper delivers all the performance you need, (up to 800 cycles per shift.)
- The D-220 is designed to grab either one or two 2-wheeled carts at the same time.
- Lifts most US style 2-wheeled carts (up to 95 gal.-360 liters) - accommodates manual loading as well.
- Thin profile for mounting on side loaders.
- Original sweeping action automatically adjusts to varying heights and uneven terrain allowing operators to mount carts or containers securely onto the Tipper lifting hook.
- Dumps deeper inside the hopper to prevent spillage and dumps higher to reduce the need to cycle the packer blade.
- Trunnion-mounted cylinder makes for easier mounting.

Specifications are subject to change without any notice or obligation on the part of the manufacturer. While due caution has been exercised in the production of this document, possible errors and omissions are unintentional.

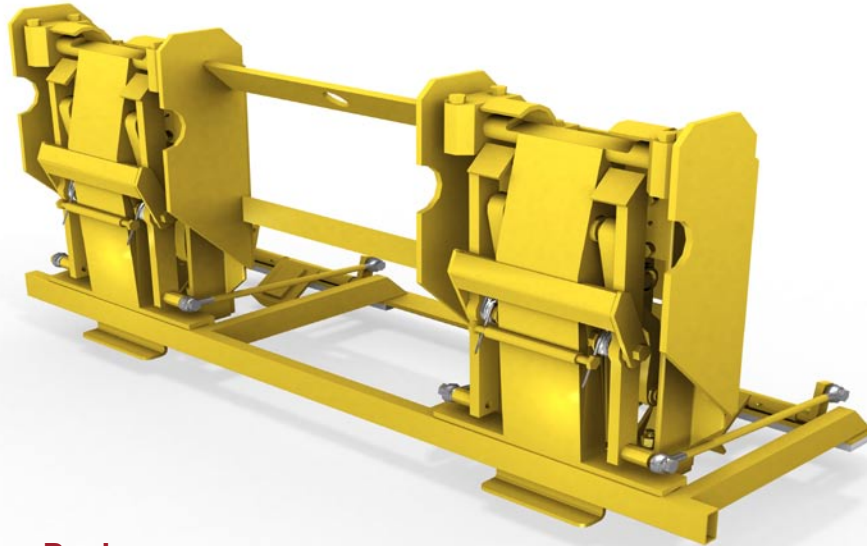
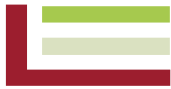

D-220 SERIES

MODEL: LDA-220

ANSI RATING:	ANSI Z 245.60-1996
LIFT TYPE:	CYLINDER
HYDRAULIC FLOW:	1.5 - 2.0 GPM
CYCLE TIME:	8-10 SECONDS
MAX. LOAD WEIGHT:	800 LBS
OPTIONS:	TAP-IN-KIT
HYDRAULIC PRESSURE:	WORKING PRESSURE - 1800 PSI - 2100 PSI
CART COMPATIBILITY:	TYPE B CARTS (DOMESTIC STYLE 2-BAR)

The **D-220** is designed to grab either one or two 2-wheeled carts at the same time. Dumps deeper inside the hopper to prevent spillage and dumps higher to reduce the need to cycle the packer blade. Thin profile for mounting on side loaders. Lifts most US style 2-wheeled carts.

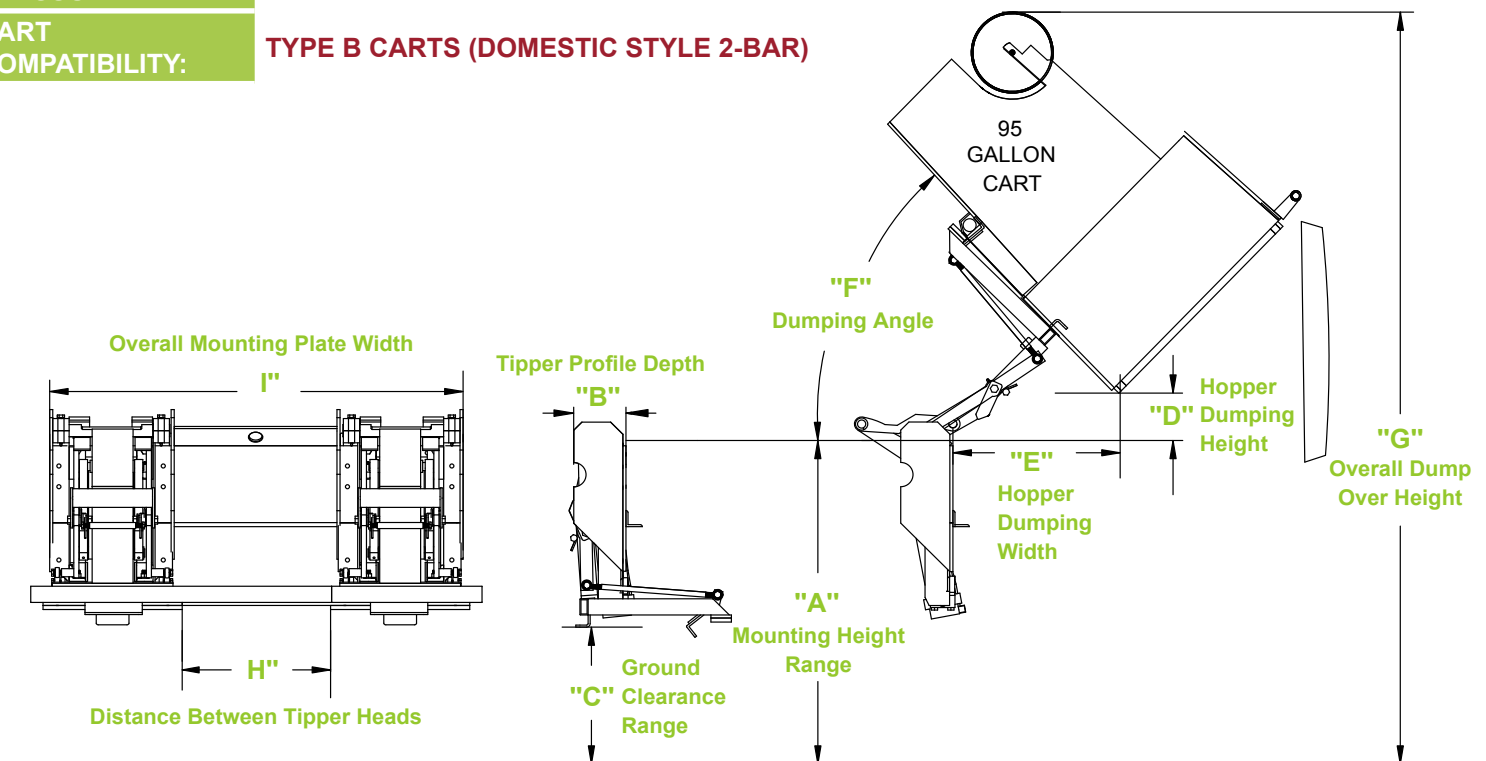

MODEL	"A" DIM.	"B" DIM.	"C" DIM.	"D" DIM.	"E" DIM.	"F" DIM.	"G" DIM.	"H" DIM.	"I" DIM.
RDA-220M Rear	38 - 44"	6 3/8"	17" - 22"	6"	19 "	50°	93" - 99"	18 1/8"	50 7/16"
RDA-220 Rear	38 - 44"	6 3/8"	17" - 22"	6"	19 "	50°	93" - 99"	2 1/2"	30"
LDA-220 Side	42 - 47"	6"	11 1/2" - 16 1/2"	10 1/2"	17 "	45°	101 1/4" - 106 1/4"	2 1/2"	30"

Dimensions accommodate most ANSI Z245.60-1996 Type B Carts (domestic style 2-bar) and most ANSI Z245.60-1996 Type C Carts (European style) Containers, but may vary due to container specifications or applications. All dimensions are approximate.



Toll Free: 1-800-711-6188