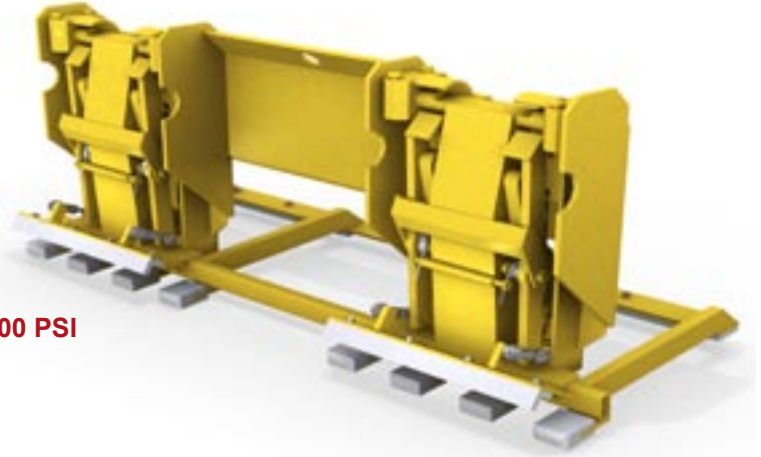

**MODEL: LDE-220**

<b>ANSI RATING:</b>	<b>ANSI Z 245.60-1996</b>
<b>LIFT TYPE:</b>	<b>CYLINDER</b>
<b>HYDRAULIC FLOW:</b>	<b>4 - 6 GPM</b>
<b>CYCLE TIME:</b>	<b>8-10 SECONDS</b>
<b>MAX. LOAD WEIGHT:</b>	<b>800 LBS</b>
<b>OPTIONS:</b>	<b>TAP-IN-KIT</b>
<b>HYDRAULIC PRESSURE:</b>	<b>WORKING PRESSURE - 1800 PSI - 2100 PSI</b>
<b>CART COMPATIBILITY:</b>	<b>TYPE C CARTS (EUROPEAN STYLE) 4-WHEELED CONTAINERS</b>

**High Efficiency Design**

The **D-220** is designed to grab either one or two 2-wheeled Carts at the same time. Dumps deeper inside the hopper to prevent spillage and dumps higher to reduce the need to cycle the packer blade. Thin profile for mounting on side loaders. Lifts most Euro Style 2-wheeled Carts and 4-wheeled Containers.

- Cylinder-powered Tipper delivers all the performance you need, (up to 800 cycles per shift.)
- The D-220 is designed to grab either one or two 2-wheeled Carts at the same time.
- Lifts most Euro Style 2-wheeled Carts and 4-wheeled Containers including Trunnion lifts (up to 290 gal.-1100 liters) - accommodates manual loading as well.
- Thin profile for mounting on side loaders.
- Original sweeping action automatically adjusts to varying heights and uneven terrain allowing operators to mount carts or containers securely onto the Tipper lifting hook.
- Dumps deeper inside the hopper to prevent spillage and dumps higher to reduce the need to cycle the packer blade.
- Trunnion-mounted cylinder makes for easier mounting.

Specifications are subject to change without any notice or obligation on the part of the manufacturer. While due caution has been exercised in the production of this document, possible errors and omissions are unintentional.



# D-220 SERIES

The **D-220** is designed to grab either one or two 2-wheeled Carts at the same time. Dumps deeper inside the hopper to prevent spillage and dumps higher to reduce the need to cycle the packer blade. Thin profile for mounting on side loaders. Lifts most Euro Style 2-wheeled Carts and 4-wheeled containers.

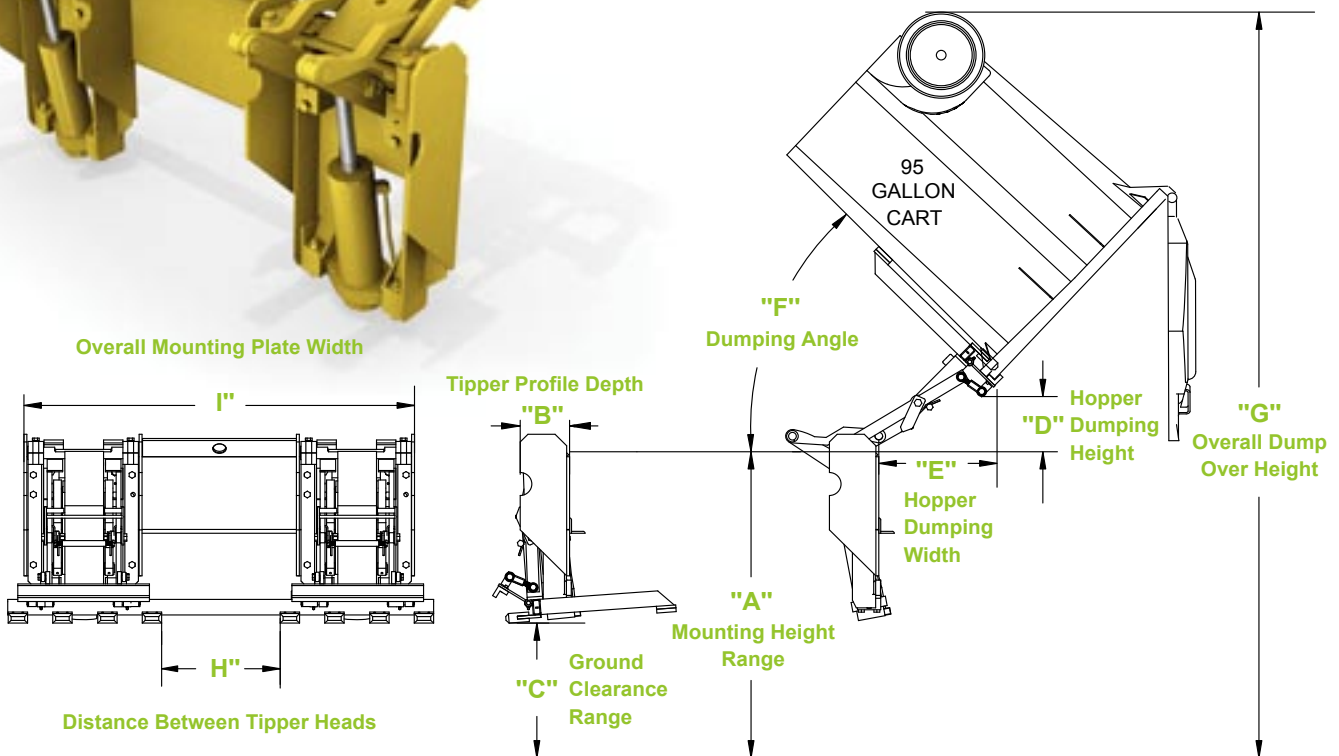

MODEL	"A" DIM.	"B" DIM.	"C" DIM.	"D" DIM.	"E" DIM.	"F" DIM.	"G" DIM.	"H" DIM.	"I" DIM.
RDT-220M Rear	38 - 44"	6 3/8"	16 1/2" - 22 1/2"	10"	17 1/4"	50°	97" - 103"	15 5/16"	50 7/16"
RDT-220 Rear	38 - 44"	6 3/8"	16 1/2" - 22 1/2"	10"	17 1/4"	50°	97" - 103"	5 5/8"	30"
LDT-220 Side	42 - 47"	6"	14 1/2" - 17 1/2"	15 1/2"	20"	45°	104 3/4" - 109 3/4"	5 5/8"	30"
RDE-220M Rear	38 - 44"	6 3/8"	15 1/2" - 21 1/2"	7"	15 1/4"	50°	95 1/2" - 101 1/2"	15 5/16"	50 7/16"
RDE-220 Rear	38 - 44"	6 3/8"	15 1/2" - 21 1/2"	7"	15 1/4"	50°	95 1/2" - 101 1/2"	5 5/8"	30"
LDE-220 Side	42 - 47"	6"	13 1/2" - 18 1/2"	11 1/2"	18"	45°	103 1/4" - 108 1/4"	5 5/8"	30"
RDA-220M Rear	38 - 44"	6 3/8"	17" - 22"	6"	19"	50°	93" - 99"	N/A	50 7/16"
RDA-220 Rear	38 - 44"	6 3/8"	17" - 22"	6"	19"	50°	93" - 99"	N/A	30"
LDA-220 Side	42 - 47"	6"	11 1/2" - 16 1/2"	10 1/2"	17"	45°	101 1/4" - 106 1/4"	N/A	30"

Dimensions accommodate most ANSI Z245.60-1996 Type B Carts (Domestic Style 2-Bar) and most ANSI Z245.60-1996 Type C Carts (European Style) Containers, but may vary due to container specifications or applications. All dimensions are approximate.



**Toll Free: 1-800-711-6188**