

MODELS: LDE-220SD / LDE-220SG

ANSI RATING:	ANSI Z 245.60-1996
LIFT TYPE:	CYLINDER
HYDRAULIC FLOW:	4 - 6 GPM
CYCLE TIME:	8-10 SECONDS
MAX. LOAD WEIGHT:	800 LBS
OPTIONS:	TAP-IN-KIT
HYDRAULIC PRESSURE:	WORKING PRESSURE - 1800 PSI - 2100 PSI
CART COMPATIBILITY:	TYPE C CARTS (EUROPEAN STYLE) 4-WHEELED CONTAINERS

**Smooth & Reliable Cart Tipper**

The **D-220S** sweeping action automatically adjusts to varying heights and uneven terrain allowing operators to mount carts or containers securely onto the Tipper lifting hook. Trunnion-mounted cylinder makes for easier mounting.

- Cylinder-powered Tipper delivers all the performance you need, (up to 800 cycles per shift.)
- Thin profile for mounting on side loaders.
- Lifts most Euro Style 2-wheeled Carts and 4-wheeled Containers (up to 290 gal.-1100 liters) - accommodates manual loading as well.
- The D-220S is designed to grab either one or two 2-wheeled Carts at the same time.
- The D-220S sweeping action automatically adjusts to varying heights and uneven terrain allowing operators to mount carts or containers securely onto the Tipper lifting hook.
- Dumps deeper inside the hopper to prevent spillage and dumps higher to reduce the need to cycle the packer blade.
- Cannot be damaged by side loader packer blade.
- Unique Trunnion cover opener system does away with protruding folding arms.
- Trunnion-mounted cylinder makes for easier mounting.

Specifications are subject to change without any notice or obligation on the part of the manufacturer. While due caution has been exercised in the production of this document, possible errors and omissions are unintentional.



D-220S SERIES



The **D-220S** sweeping action automatically adjusts to varying heights and uneven terrain allowing operators to mount carts or containers securely onto the Tipper lifting hook. Trunnion-mounted cylinder makes for easier mounting.

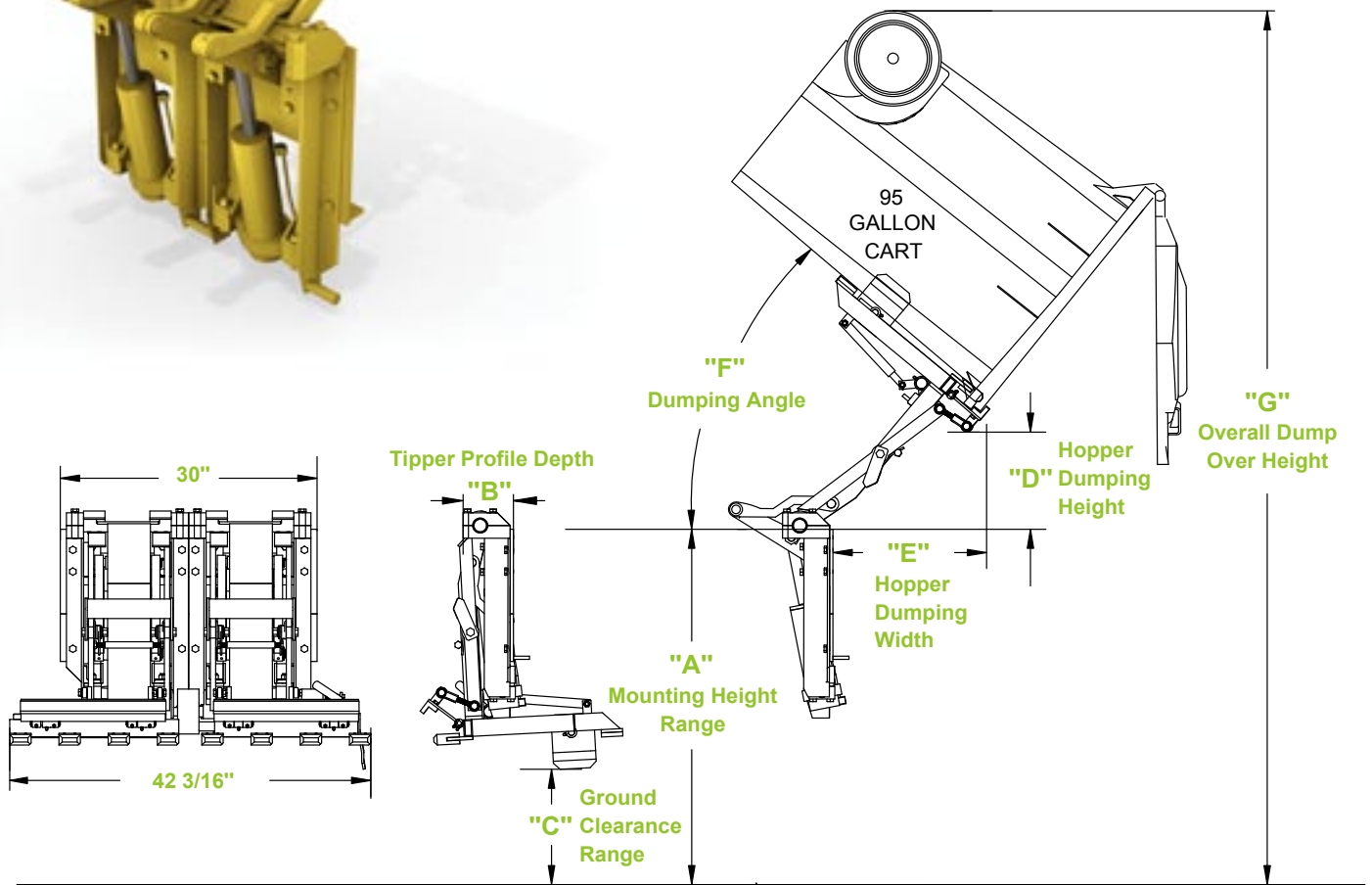

MODEL	"A" DIM.	"B" DIM.	"C" DIM.	"D" DIM.	"E" DIM.	"F" DIM.	"G" DIM.
LDE-220SD Side (right) loader	42 - 47"	6"	13 1/2" - 18 1/2"	11 1/2"	18"	45°	103 1/4" - 108 1/4"
LDE-220SG Side (left) loader	42 - 47"	6"	13 1/2" - 18 1/2"	11 1/2"	18"	45°	103 1/4" - 108 1/4"

Dimensions accommodate most ANSI Z245.60-1996 Type B Carts (Domestic Style 2-Bar) and most ANSI Z245.60-1996 Type C Carts (European Style) Containers, but may vary due to container specifications or applications. All dimensions are approximate.



Toll Free: 1-800-711-6188