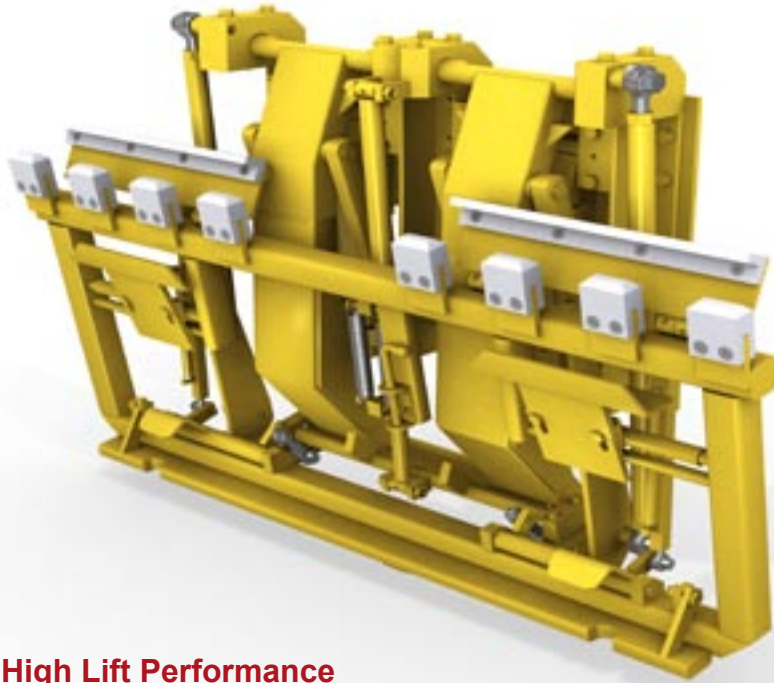

MODEL: LDT-330

Designed for High Lift Performance

The **D-330** lifts and dumps higher to reduce the need to cycle the packer blade. The **D-330** is designed to grab either one or two 2-wheeled Carts at the same time. Unique lifting motion automatically adjusts to varying heights and uneven terrain allowing operators to mount carts securely onto the Tipper lifting hook.

- Cylinder-powered Tipper delivers all the performance you need, (up to 800 cycles per shift.)
- Lifts most Domestic and Euro Style 2-wheeled Carts (up to 95 gal. - 360 liters) - accommodates manual loading as well.
- The D-330 is designed to grab either one or two 2-wheeled Carts at the same time.
- Unique lifting motion automatically adjusts to varying heights and uneven terrain allowing operators to mount carts securely onto the Tipper lifting hook.
- The D-330 lifts and dumps higher to reduce the need to cycle the packer blade.
- Cannot be damaged by the packer blade.
- Trunnion-mounted cylinder makes for easier mounting.

Specifications are subject to change without any notice or obligation on the part of the manufacturer. While due caution has been exercised in the production of this document, possible errors and omissions are unintentional.



D-330 SERIES

MODEL: LDT-330

ANSI RATING:	ANSI Z 245.60-1996
LIFT TYPE:	CYLINDER
HYDRAULIC FLOW:	4 - 6 GPM
CYCLE TIME:	8-10 SECONDS
MAX. LOAD WEIGHT:	700 LBS
OPTIONS:	TAP-IN-KIT
HYDRAULIC PRESSURE:	WORKING PRESSURE - 1800 PSI - 2100 PSI
CART COMPATIBILITY:	TYPE B CARTS (DOMESTIC STYLE 2-BAR) TYPE C CARTS (EUROPEAN STYLE)

The D-330 lifts and dumps higher to reduce the need to cycle the packer blade. The D-330 is designed to grab either one or two 2-wheeled Carts at the same time. Unique lifting motion automatically adjusts to varying heights and uneven terrain allowing operators to mount carts securely onto the Tipper lifting hook.

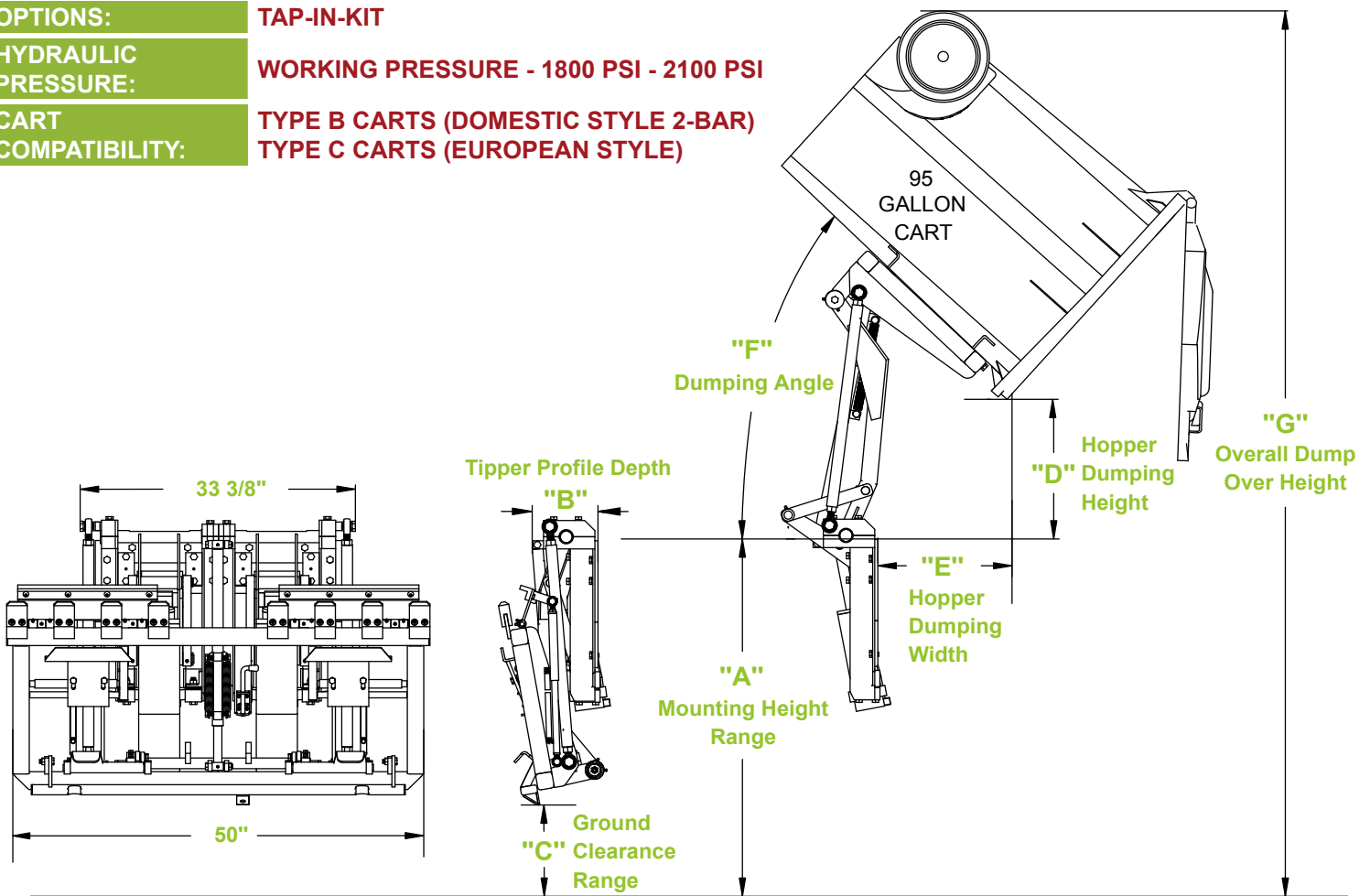

MODEL	"A" DIM.	"B" DIM.	"C" DIM.	"D" DIM.	"E" DIM.	"F" DIM.	"G" DIM.
LDT-330 Side loader	44 - 47"	8"	14 1/2" - 17 1/2"	23"	15"	40°	109 1/2" - 112 1/2"

Dimensions accommodate most ANSI Z245.60-1996 Type B Carts (Domestic Style 2-Bar) and most ANSI Z245.60-1996 Type C Carts (European Style) Containers, but may vary due to container specifications or applications. All dimensions are approximate.



Toll Free: 1-800-711-6188