

MODEL: DCD-113UDA

ANSI RATING:	ANSI Z 245.60-1996
LIFT TYPE:	CYLINDER
HYDRAULIC FLOW:	4 - 6 GPM
CYCLE TIME:	8-10 SECONDS
MAX. LOAD WEIGHT:	1500 LBS
OPTIONS:	TAP-IN-KIT
HYDRAULIC PRESSURE:	WORKING PRESSURE - 1800 PSI - 2100 PSI
CART COMPATIBILITY:	TYPE B CARTS (DOMESTIC STYLE 2-BAR)

**Dock and Ground Level Tipper**

- Cylinder-powered Tipper delivers all the performance you need, (up to 800 cycles per shift.)
- Designed to grab either one or two Domestic Style 2-wheeled Carts (up to 95 gal.-360 liters) - accommodates manual loading as well.
The DCD-113 dock-level dumper is used to dump containers that are rolled
- directly onto a loading dock or at ground level. Units can dump containers of up to 1,500 lbs from a 48" loading dock safely and effortlessly.
- Vertical lifting action automatically adjusts to varying heights and uneven terrain allowing operators to mount carts or containers securely onto the Tipper lifting hook.
- Lifts and dumps higher to reduce the need to cycle the packer blade.
- Cannot be damaged by the packer blade.
- Used for heavy duty load application on rear loaders.
- Dock level loading provides ease of operation.
- Unique Trunnion cover opener system does away with protruding folding arms.

Specifications are subject to change without any notice or obligation on the part of the manufacturer. While due caution has been exercised in the production of this document, possible errors and omissions are unintentional.



DCD-113 *SERIES*

The **DCD-113** dock-level dumper is used to dump containers that are rolled directly onto a loading dock or at ground level. Units can dump containers of up to 1,500 lbs from a 48" loading dock safely and effortlessly. Used for heavy duty load application on rear loaders.

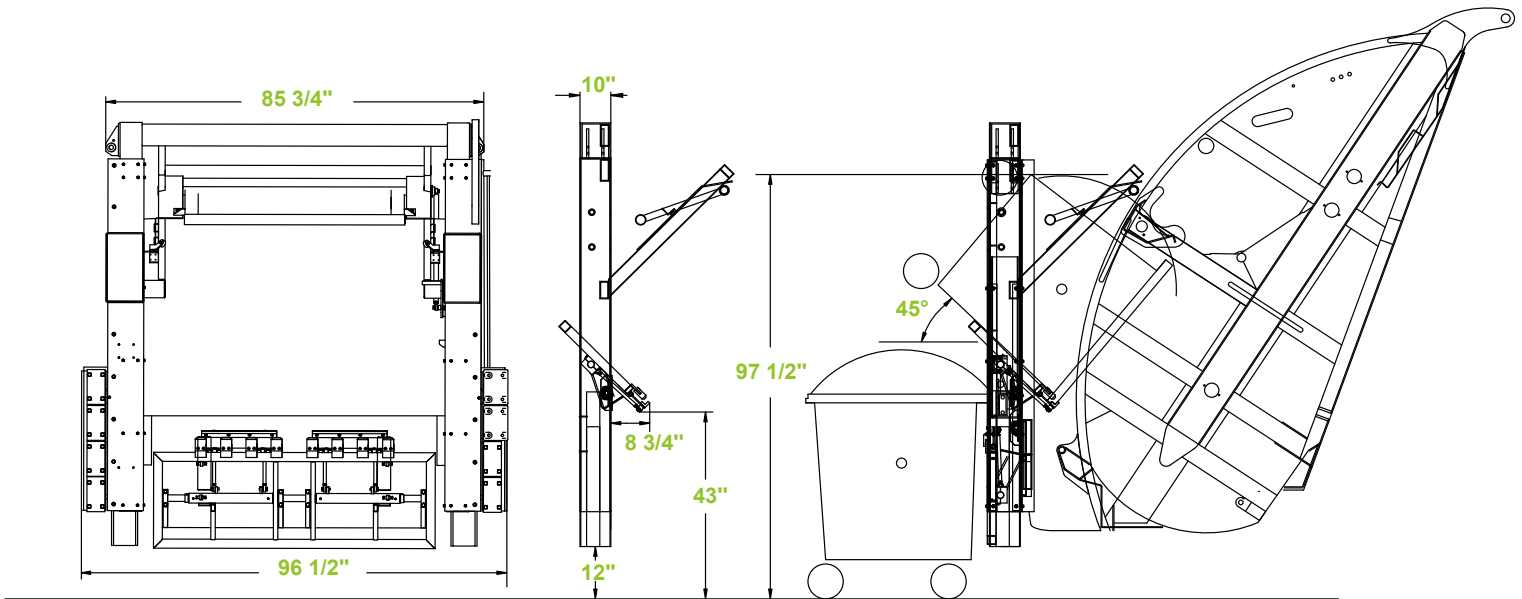

Specifications

Dimensions accommodate most ANSI Z245.60-1996 Type B Carts (Domestic Style 2-Bar) and most ANSI Z245.60-1996 Type C Carts (European Style) Containers, but may vary due to container specifications or applications. All dimensions are approximate.



Toll Free: 1-800-711-6188

www.IndustrialLifters.com
© BDFG & Industrial Lifters
Printed in Canada - # GIL-121-2005