

MODEL: LEF-220

ANSI RATING:	ANSI Z 245.60-1996
LIFT TYPE:	CYLINDER
HYDRAULIC FLOW:	2 - 3 GPM
CYCLE TIME:	8-10 SECONDS
MAX. LOAD WEIGHT:	650 LBS
OPTIONS:	TAP-IN-KIT
HYDRAULIC PRESSURE:	WORKING PRESSURE - 1800 PSI - 2100 PSI
CART COMPATIBILITY:	TYPE C CARTS (EUROPEAN STYLE)

**Compact Short Arm Heavy Duty Tipper**

- Cylinder-powered Tipper delivers all the performance you need, (up to 800 cycles per shift.)
- The F-220 is used for heavy duty load applications on rear-, side-, and front-loaders
- Mounts on a removable mounting plate with minimal cutting into the sill, for easy maintenance and replacement. (CC-220 units mount to a front-load carry can.)
- Lifts most Euro Style 2-wheeled Carts (up to 95 gal. - 360 liters)
- accommodates manual loading as well.
- Original sweeping action automatically adjusts to varying heights and uneven terrain allowing operators to mount carts securely onto the Tipper lifting hook.
- Tipper profile does not interfere with packer blade on rear and side loaders and cannot be damaged by the packer blade.
- Narrow design allows for installation of 2 lifters on the same rear loader for increased productivity.

Specifications are subject to change without any notice or obligation on the part of the manufacturer. While due caution has been exercised in the production of this document, possible errors and omissions are unintentional.



F-220 SERIES



The **F-220** is used for heavy duty load application on rear-, side- and front-loaders. (CC-220 units mount to a front-load carry can.) Original sweeping action automatically adjusts to varying heights and uneven terrain allowing operators to mount carts securely onto the Tipper lifting hook.

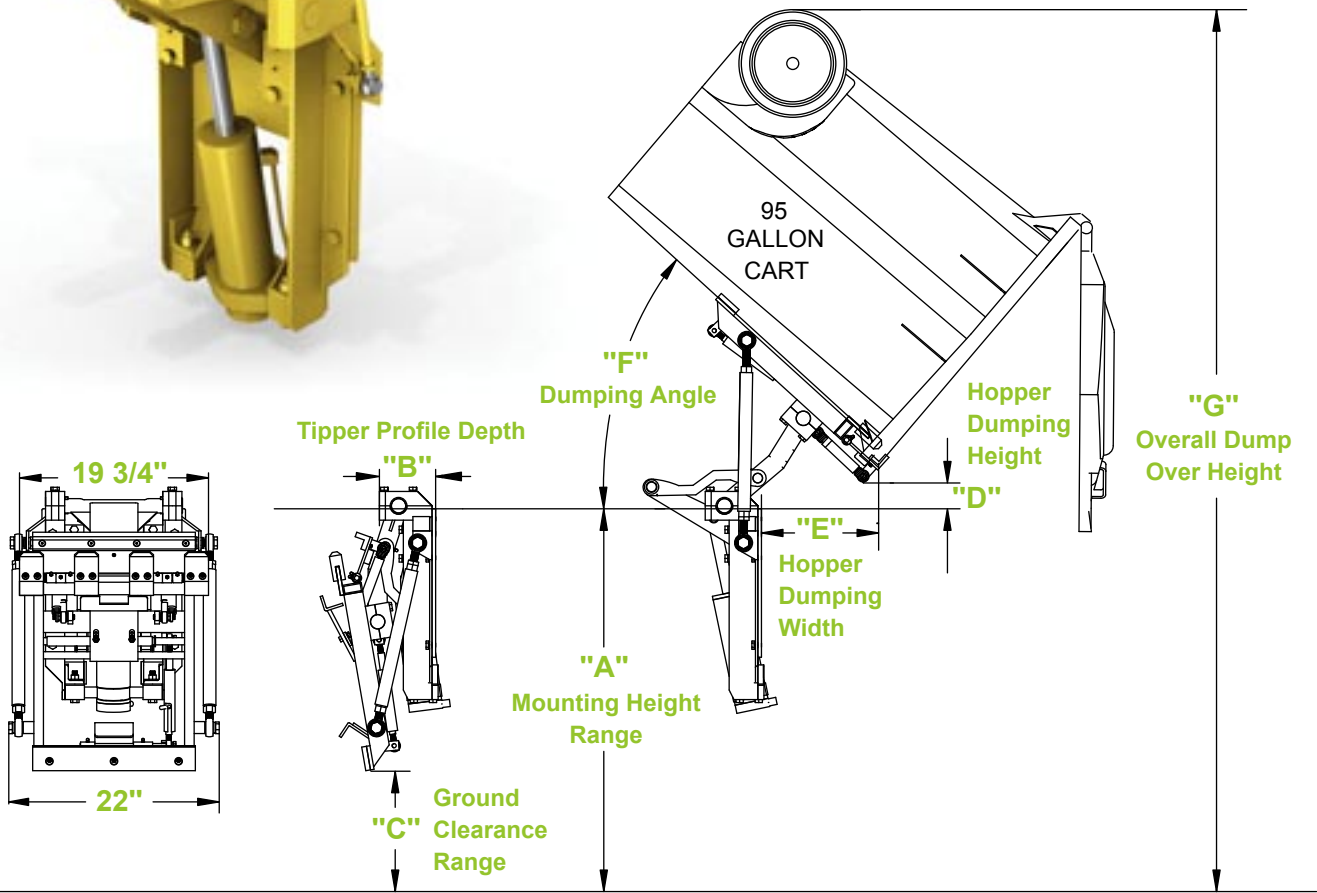

MODEL	"A" DIM.	"B" DIM.	"C" DIM.	"D" DIM.	"E" DIM.	"F" DIM.	"G" DIM.
LEF-220 Rear loader	38 - 44"	6"	10 1/2" - 16 1/2"	2 - 5/8"	12 1/2"	45°	90 1/4" - 96 1/4"
LEF-220 Side loader	42 - 47"	6"	14 1/2" - 19 1/2"	2 - 5/8"	12 1/2"	45°	94 1/4" - 99 1/4"

Dimensions accommodate most ANSI Z245.60-1996 Type B Carts (Domestic Style 2-Bar) and most ANSI Z245.60-1996 Type C Carts (European Style) Containers, but may vary due to container specifications or applications. All dimensions are approximate.



Toll Free: 1-800-711-6188