

Model	Compatible Containers
CD-111-CT	2-Wheel Domestic & European Style Carts
CD-111-CE	2-Wheel European Style Carts
CD-111-CA	2-Wheel Domestic Style Carts
CD-111-CC	Gaylords, Drums, Barrels, Baskets & others

MOUNTED ON EQUIPMENT

CONTAINER CAPACITY	35-95 GAL (140-360 LITERS)
MAX. LOAD WEIGHT	UP TO 500 LBS (227 KG)
DUMPING HEIGHT	36" - 84"
LIFTER MOUNT TYPE	MOUNTED ON EQUIPMENT
LIFT MECHANISM	CYLINDER
CONTAINER TYPE	2-WHEEL DOMESTIC (2-BAR) CARTS 2-WHEEL EUROPEAN CARTS, DRUMS, BARRELS, BASKETS & OTHERS

The Ultimate Innovation in Container Lifting Technology

The CD-111 Series lifter is designed especially for facilities that need to lift and dump 2-Wheel Carts weighing up to 500 lbs. With discharge heights from ground level to 84", the CD-111 is ideal for mounting on compactors and other equipment and is also available in both a stationary or portable configuration.

- Lifts standard 2-Wheel Domestic and Euro Style Carts, 35 - 95 gal. (140 - 360 liters).
- Stand available in right or left hand configuration.
- Stand must be bolted to compactor wall.
- Up to 45-degree Dump Angle for complete container emptying.

Custom Adapters Available to Accommodate all Types and Sizes of Drums, Barrels, Baskets or any other Non-Standard Carts or Containers.

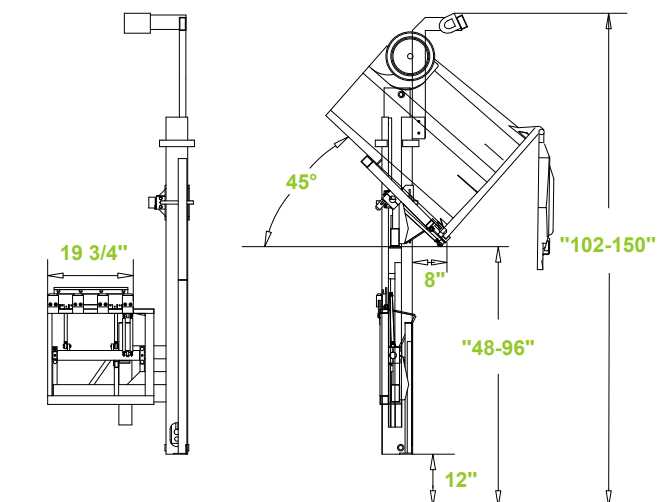

Dimensions accommodate most ANSI Z245.60-1996 Type B Carts (domestic style 2-bar) and most ANSI Z245.60-1996 Type C Carts (European style) Containers, but may vary due to container specifications or applications. All dimensions are approximate.



CD-111-CE

