



Model	Compatible Containers
<b>CD-111-RT</b>	2-Wheel Domestic & European Style Carts
<b>CD-111-RE</b>	2-Wheel European Style Carts
<b>CD-111-RA</b>	2-Wheel Domestic Style Carts
<b>CD-111-RC</b>	Gaylords, Drums, Barrels, Baskets & others

## MOBILE ON WHEELS

<b>CONTAINER CAPACITY</b>	<b>35-95 GAL (140-360 LITERS)</b>
<b>MAX. LOAD WEIGHT</b>	<b>UP TO 500 LBS (227 KG)</b>
<b>DUMPING HEIGHT</b>	<b>36" - 84"</b>
<b>LIFT MECHANISM</b>	<b>CYLINDER</b>
<b>CONTAINER TYPE</b>	<b>2-WHEEL DOMESTIC (2-BAR) CARTS 2-WHEEL EUROPEAN CARTS, DRUMS, BARRELS, BASKETS &amp; OTHERS</b>

## The Ultimate Innovation in Container Lifting Technology

The CD-111 Series lifter is designed especially for facilities that need to lift and dump 2-Wheel Carts weighing up to 500 lbs. With discharge heights from ground level to 84", the CD-111 has a small enough footprint allowing it to be sited anywhere space is a concern. The CD-111 is available in both a stationary or portable configuration that can be moved and used everywhere.

- Lifts 2-Wheel Domestic and Euro Style Carts, 35 - 95 gal. (140 - 360 liters).
- Stand available in right or left hand configuration.
- Stationary or mobile (optional locking casters for mobile applications).
- Up to 45-degree Dump Angle for complete container emptying.
- Heavy-duty castor wheels.

Custom Adapters Available to Accomodate all Types and Sizes of Drums, Barrels, Baskets or any other Non-Standard Carts or Containers.

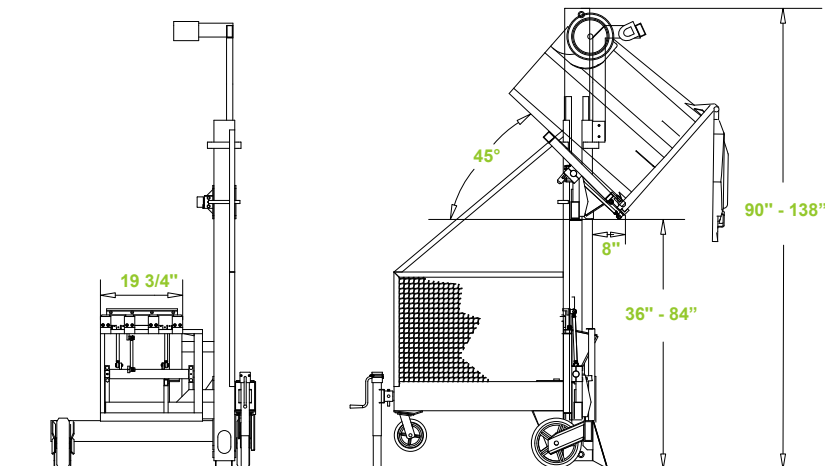

**CD-111-RE**



Specifications are subject to change without any notice or obligation on the part of the manuf. While due caution has been exercised in the production of this document, possible errors and omissions are unintentional.

Features & Benefits