



## GROUND OR DOCK MOUNTED

<b>CONTAINER CAPACITY</b>	<b>35-95 GAL (140-360 LITERS)</b>
<b>MAX. LOAD WEIGHT</b>	<b>UP TO 500 LBS (227 KG)</b>
<b>DUMPING HEIGHT</b>	<b>36" - 84"</b>
<b>LIFT MECHANISM</b>	<b>CYLINDER</b>
<b>CONTAINER TYPE</b>	<b>2-WHEEL DOMESTIC (2-BAR) CARTS 2-WHEEL EUROPEAN CARTS, DRUMS, BARRELS, BASKETS &amp; OTHERS</b>

## The Ultimate Innovation in Container Lifting Technology

The CD-111 Series lifter is designed especially for facilities that need to lift and dump 2-Wheel Carts weighing up to 500 lbs. With discharge heights from ground level to 84", the CD-111 has a small enough footprint allowing it to be sited anywhere space is a concern. The CD-111 is available in both a stationary or portable configuration. The CD-111 is ideal for mounting on compactors and other equipment or as a portable model that can be moved and used anywhere.

- Lifts standard 2-Wheel Domestic and Euro Style Carts, 35 - 95 gal. (140 - 360 liters).
- Stand available in right or left hand configuration.
- Unique and versatile lifter designed for dumping waste or recyclables into compactors, shredders, crushers, or any other processing, transfer or material handling equipment.
- Stand must be anchored to floor.
- Up to 45-degree Dump Angle for complete container emptying.

Custom Adapters Available to Accomodate all Types and Sizes of Drums, Barrels, Baskets or any other Non-Standard Carts or Containers.



**CD-111-E**

Specifications are subject to change without any notice or obligation on the part of the manufacturer. While due caution has been exercised in the production of this document, possible errors and omissions are unintentional.



Features & Benefits

# CD-111 SERIES

Model	Compatible Containers
<b>CD-111-T</b>	2-Wheel Domestic & European Style Carts
<b>CD-111-E</b>	2-Wheel European Style Carts
<b>CD-111-A</b>	2-Wheel Domestic Style Carts
<b>CD-111-C</b>	Gaylords, Drums, Barrels, Baskets & others

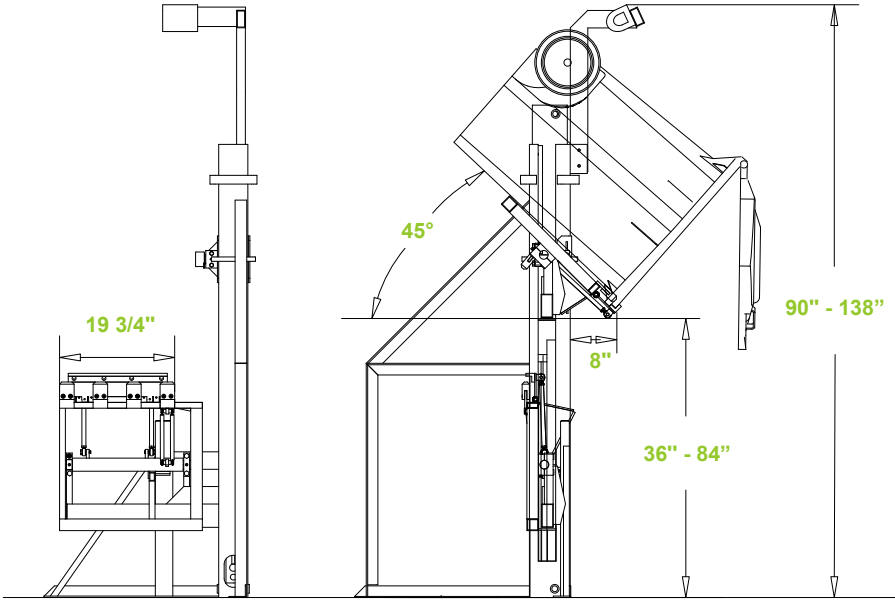

Specifications

Dimensions accommodate most ANSI Z245.60-1996 Type B Carts (domestic style 2-bar) and most ANSI Z245.60-1996 Type C Carts (European style) Containers, but may vary due to container specifications or applications. All dimensions are approximate.