

GROUND OR DOCK MOUNT

CONTAINER CAPACITY	35-95 GAL (140-360 LITERS)
MAX. LOAD WEIGHT	UP TO 500 LBS (227 KG)
DUMPING HEIGHT	4 - 20 FEET
LIFT MECHANISM	HYDRAULIC OR ELECTRIC MOTOR
CONTAINER TYPE	2-WHEEL DOMESTIC (2-BAR) CARTS 2-WHEEL EUROPEAN CARTS, GAYLORDS, DRUMS, BARRELS, BASKETS & OTHERS

Versatile Compact Design Gives You Multi-Use Capabilities

The CD-210 is designed especially for facilities that need to operate with hydraulic oil (Hydraulic Motor) or without hydraulic oil (Electric Model). The CD-210 is capable of lifting and dumping 2-Wheel Carts and other Containers of up to 500 lbs. from 4 - 20 feet. The CD-210 is compact enough to fit in the tightest spaces for ease of maneuverability around the unit. Units are powered and come supplied with self-contained electric or hydraulic motors.



CD-210-E

- Lifts standard 2-Wheel Domestic and Euro Style Carts, 35 - 95 gal. (140 - 360 liters).
- Candy cane design dumps deep inside the hopper.
- Unique and versatile lifter designed for dumping waste or recyclables into compactors, shredders, crushers, or any other processing, transfer or material handling equipment.
- Completely electrical, including starter; easy to install and ready to operate.
- Adapts to any voltage requirements.
- Stand must be anchored to floor.
- Up to 45-degree Dump Angle for complete container emptying.

Custom Adapters Available to Accomodate all Types and Sizes of Drums, Barrels, Baskets or any other Non-Standard Carts or Containers.

Specifications are subject to change without any notice or obligation on the part of the manufacturer. While due caution has been exercised in the production of this document, possible errors and omissions are unintentional.



www.IndustrialLifters.com

CD-210 SERIES



Model	Compatible Containers	Lift Mechanism
CD-210-T	2-Wheel Domestic & European Style Carts	Hydraulic Motor
CD-210-E	2-Wheel European Style Carts	Hydraulic Motor
CD-210-A	2-Wheel Domestic Style Carts	Hydraulic Motor
CD-210-C	Gaylords, Drums, Barrels, Baskets & others	Hydraulic Motor
CD-120-ET	2-Wheel Domestic & European Style Carts	Electric Motor
CD-210-EE	2-Wheel European Style Carts	Electric Motor
CD-210-EA	2-Wheel Domestic Style Carts	Electric Motor
CD-210-EC	Gaylords, Drums, Barrels, Baskets & others	Electric Motor

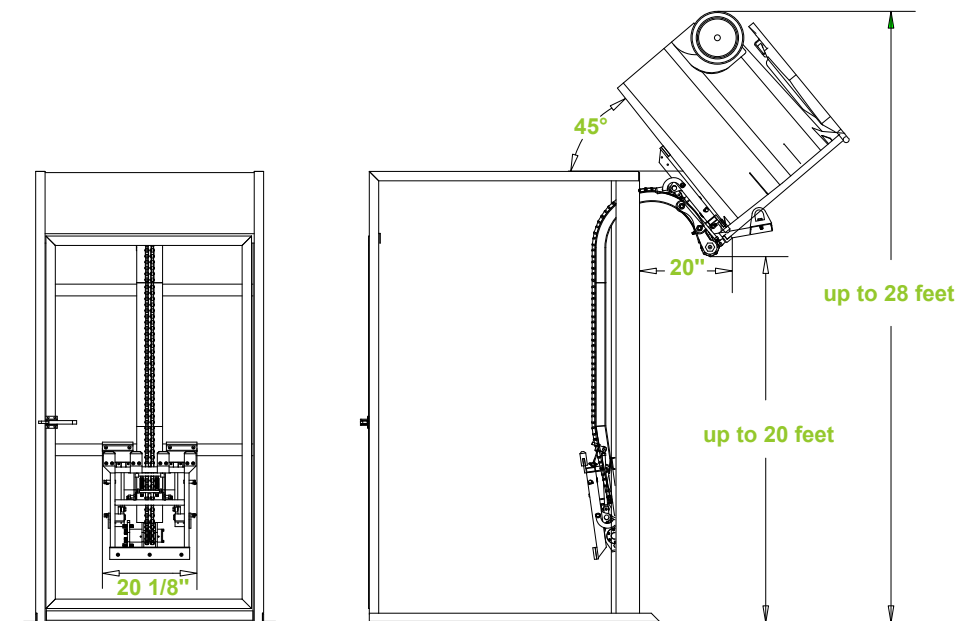

Specifications

Dimensions accommodate most ANSI Z245.60-1996 Type B Carts (domestic style 2-bar) and most ANSI Z245.60-1996 Type C Carts (European style) Containers, but may vary due to container specifications or applications. All dimensions are approximate.

VERTI
LIFTER®

Toll Free: 1-800-711-6188

www.IndustrialLifters.com

© BDFG & Industrial Lifters

Printed in Canada - # GIL-121-2005